

AVAILABLE THROUGH
 FENCEWORKS INC.
 1-800-788-5620

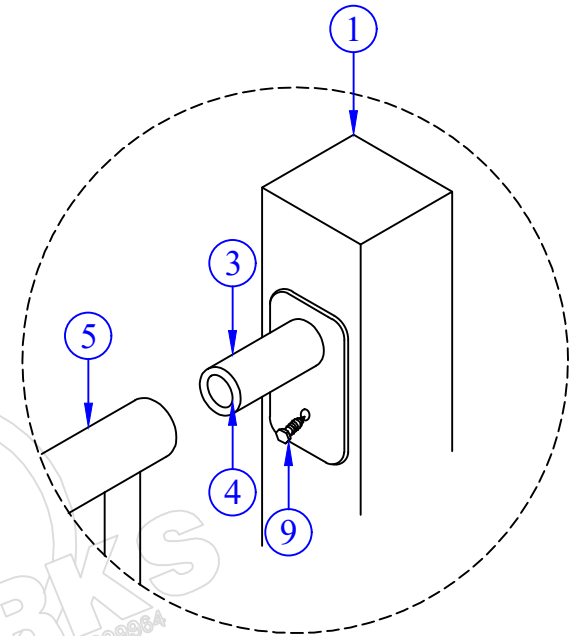
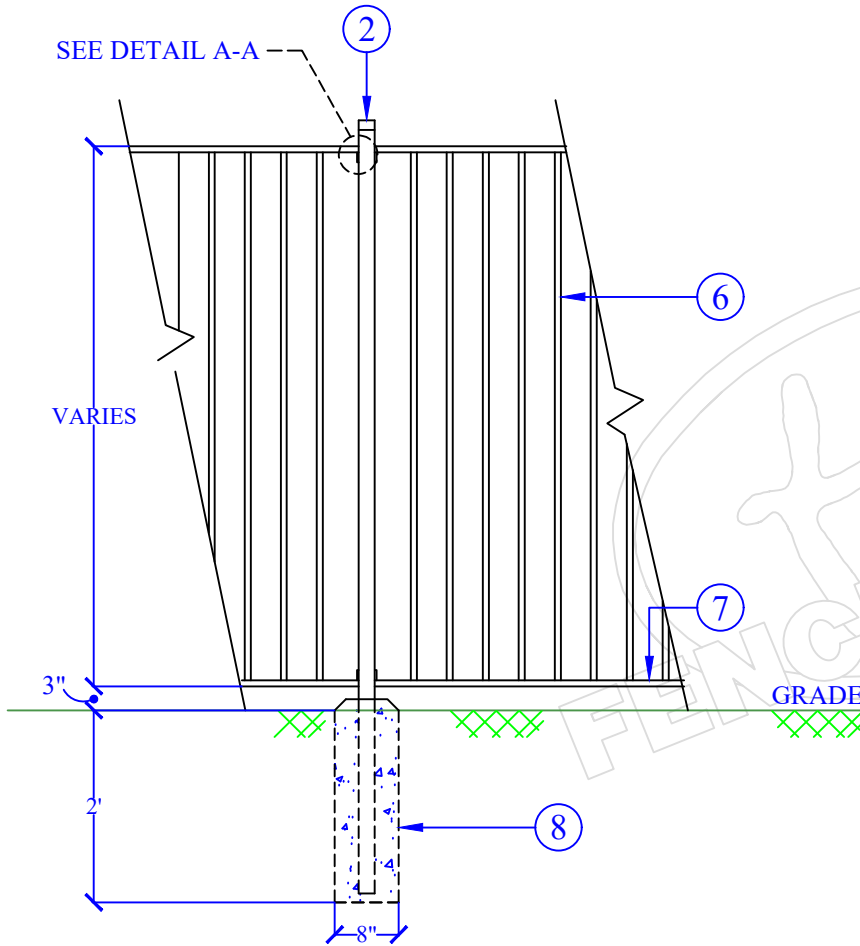

BRACKET ATTACHMENT DETAIL A-A

LEGEND

1. 2" X 2" FENCE POST (OR BLOCK PORTION OF WALL/PILASTER).
2. 2" SQ. TUBULAR STEEL POST W/ CAP @ 8'-0" O.C. MAX. (16 GA.)
3. OUTSIDE DIAMETER SLIGHTLY LESS THAN INSIDE DIAMETER OF TOP OR BOTTOM RAIL.
4. CAULK JOINT W/ CLEAR SILICON.
5. FENCE RAIL SLIPS OVER POST ASSEMBLY.
6. 3/4" ROUND PICKETS @ 4-1/2" O.C. (18 GA.)
7. 1-3/8" ROUND TUBULAR STEEL RAILS TOP & BOTTOM. (16 GA.)
8. 8" X 24" DOMED CONCRETE FOOTING.
9. TEK. SCREW #9

NOTE:

- ALL MATERIAL TO BE PRE-GALVANIZED.
- PAINT WITH ONE COAT EPOXY PRIMER & ONE COAT POLYURETHANE FINISH COLOR BY OWNER.

SCALE: NTS UNLESS NOTED

DETAIL NO.

0/1-002

LICENSE NO.

299964

FW-CALIFORNIA ROUND TUBULAR STEEL FENCE

WEBSITE

WWW.FENCEWORKS.US

PHONE NO.

(800) 350-5620

LOCATION:
 ANAHEIM
 RIVERSIDE
 FRESNO
 PALMDALE
 MANTECA
 SACRAMENTO
 BAKERSFIELD
 SANTA PAULA
 FALLBROOK

